

TECHNICAL FEATURES

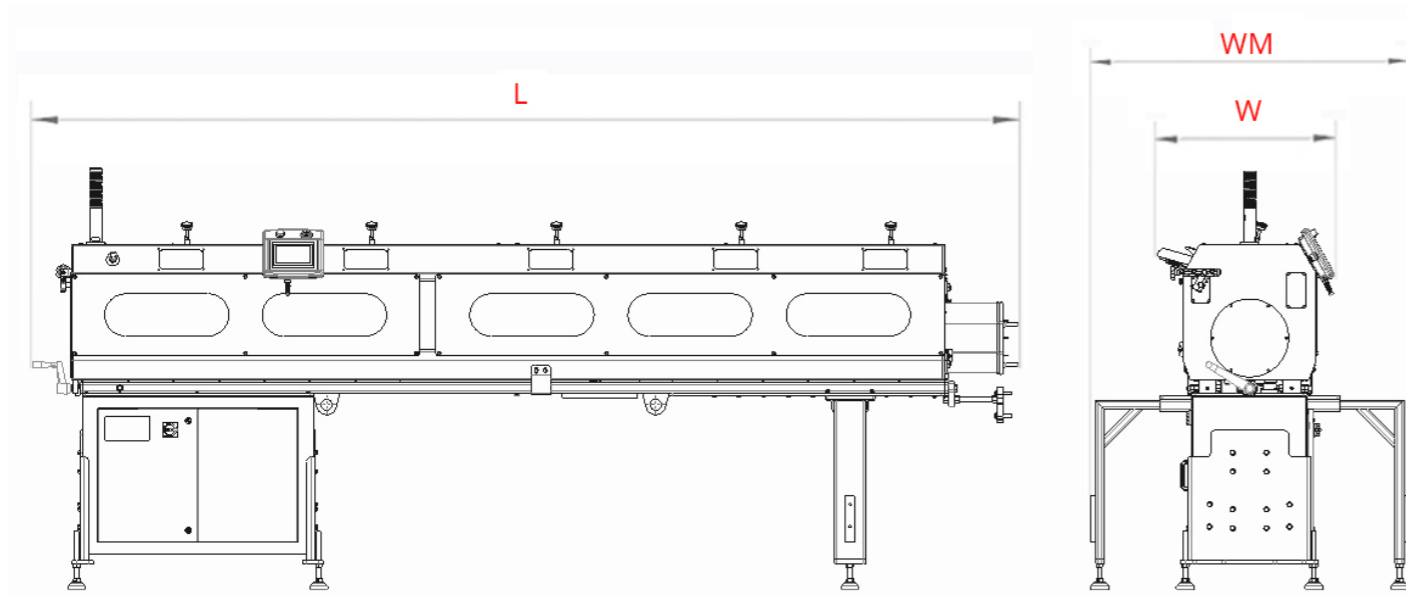

Bar Length	2900 - 3300 mm
L - Total Length	for GM/GS/AS 20 and Var.25: 4365mm (+850mm to slide the upper frame) for Mori Say 620: 4455mm (+850mm to slide the upper frame)
W - Width	806mm
WM - Width with front legs	for GM/GS/AS 20 and Var.25: 1250mm for Mori Say 620: 1430mm
Weight	1500kg

CHARACTERISTICS

1. Lathe downtime reduction
2. Fast channels replacement
3. Fast cartridges replacement
- 4.a Bar loading with accelerated time for Mori Say 620
- 4.b Bar loading in masked time for GM/GS/AS 20 and Var. 25
5. Channel guide made of wear resistant plastic material
6. Bars rack capacity: 480mm
7. Sliding upper frame

Option

- . Channels Kit
- . Cartridges Kit

TECHNICAL DATA

Bar diameters	Depending on lathe model (Standard min Ø 5mm max Ø 25mm) Special Ø on demand
Bar Length	2900mm - 3300mm
Bar Rack capacity	Standard 480mm (19")
Bar feeding	Electric
Bar change time	Preload: 3s (if the time piece > 3s completely hidden time) Introduction: 8s-12s Depending on the round bar length (2,9m/3,3m)

FAST CHANNELS REPLACEMENT

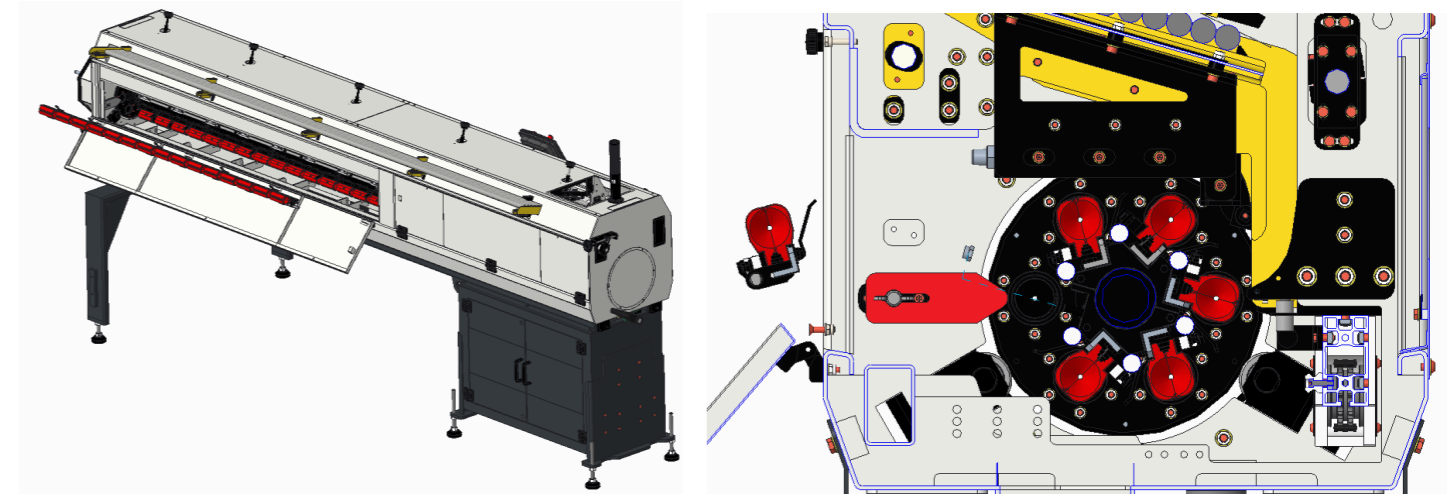

FAST CARTRIDGES REPLACEMENT

